



www.truativ.com

2001/2002 Cranks - Spline/Square

## Installation and Service Guide

Every effort has been made to guarantee superior design and workmanship on our products. To ensure correct installation and performance we recommend the services of a qualified, professional bicycle technician. If you are adventurous and plan to install these parts yourself, please read this entire manual carefully before proceeding.

TRUVATIV assumes no responsibility for malfunction or injury caused by faulty installation or maintenance. You should be aware that bolts can rattle loose and parts may be damaged after a crash. All parts must be frequently checked and serviced to ensure safety.

## Parts & Tools

### Parts:

- 4 or 5 Arm Crank, left and right sides
- One of the following:
  - Outer Chaining (aluminum)
  - Outer Chaining (steel)
- One of the following:
  - Middle Chaining (aluminum)
  - Middle Chaining (steel)
- One or none of the following:
  - Inner Chaining (aluminum)
  - Inner Chaining (steel)
- 8-10 pieces M8-8mm long Allen bolts
- 4-5 pieces M8-9mm long T-Nuts
- One of the following:
  - 2 pieces M8 crank bolts (Square Bottom Bracket)
  - 2 pieces M15 or M12 crank bolts
  - 2 pieces ISIS Drive washers (Splined Bottom Bracket)

### Optional:

- 1 piece AEROGUARD chain guard
- 4 pieces M3 7-9mm long Phillips screws
- 2 pieces pedal washers

### Tools:

- 5 & 8mm Allen key torque wrench
- Chaining bolt spanner
- Phillips screwdriver (optional)
- Loctite™ 222

## Chaining Assembly

**Note:** Always use TRUVATIV replacement parts for optimum performance. TRUVATIV chainrings are date coded (1999, 2000, etc.) and must be used together with rings from the same date code. Shifting performance may be severely impacted if rings with different date codes are mixed within an assembly.

### STEP 1: Outer & Middle Ring Assembly.

Slide the outer chaining over the crank arm (Figure 1).

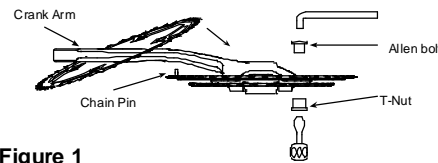

Figure 1

The chain pin on the outer chaining should be pointing toward the crank arm and aligned with the centerline of the crank arm. Align the mounting holes on the chaining with the corresponding holes on the crank spider. Turn the crank and chaining over and adjoin the middle chaining to the crank spider. Align the mounting holes. Make sure that you can read the text embossed on the outer and middle chainrings. The index marks of both chainrings should line up (Figure 2).

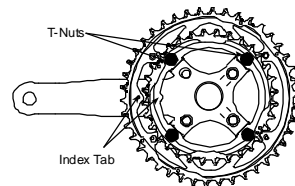

Figure 2

Insert the slightly greased steel M8 Allen bolts into the mounting holes opposite the crank arm. If supplied with aluminum bolts, apply Loctite™ 222 instead of grease. Screw on the long T-nuts. Make sure that the chainrings are seated correctly then tighten to the torque requirements in Figure 3.

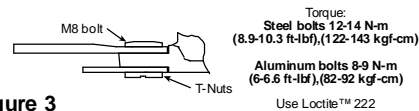

Figure 3

### STEP 2: Inner Chaining Assembly.

Hold the assembly so the middle chaining is facing up. Lay the inner chaining on top of the assembly so the mounting holes line up with the unused threaded holes in the crank spider. Make sure that the embossed text faces up and the alignment tab is aligned with the tab on the middle chaining. Insert a slightly greased steel allen bolt into each screw hole and tighten to the torque requirements in Figure 4; do not use aluminum bolts for the small chaining. At this point, the right crank assembly should look like Figure 4.

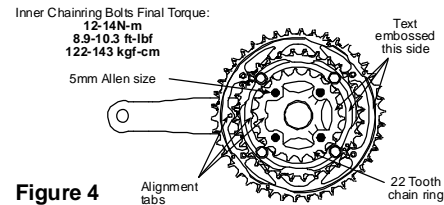

Figure 4

### STEP 3: Optional AEROGUARD Assembly.

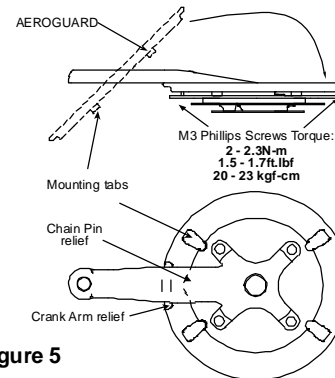

Figure 5

Insert the M3 Phillips screws from the back into the AEROGUARD and tighten to the torque requirements shown in Figure 5.

## Assembly Onto Bottom Bracket

**Square:** Install cranks onto a **clean, grease-free** surface. Refer to the specifications in Figure 6 before installation.

**Spline:** First, confirm that ISIS Drive washers are installed between the crank arm and crank bolt. Next, install spline cranks onto well greased spindle. Also, be sure to grease the stops on the bottom bracket spindle. Refer to the specifications in Figure 6 before installation.

Install the crank assembly as specified and shown in Figure 6. Grease the bottom bracket bolt threads and under the bolt head, then tighten to the torque requirements specified in Figure 6. For proper installation, always use a torque wrench.

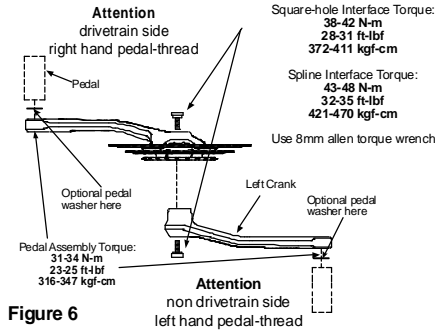
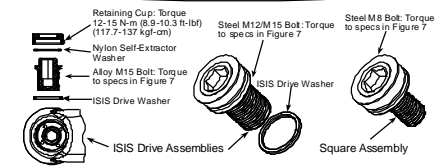

Figure 6

### Note:

1. Use Shimano 8-speed chain for 22-32-42 and Shimano 9-speed chain for all other ring combinations.

## Bolt Assembly



## Compatibility

Model	BB Shell	Chainline	E-type FD or Chainguide
BB-02-SPL-SL-108/68	68mm wide	44.5 road double	not compatible (NO spacer)
BB-02-SPL-SL-113/68	68mm wide	48.5 mb	not compatible (ONE spacer)
BB-02-SPL-SL-113/68E	68mm wide	48.5 mb	compatible (NO spacer)
BB-02-SPL-SL-113/73	73mm wide	48.5 mb	not compatible (NO spacer)
BB-02-SPL-SL-118/68	68mm wide	51 mb / 46.5 road t.	not compatible (ONE spacer)
BB-02-SPL-SL-118/68E	68mm wide	51 mb	compatible (NO spacer)
BB-02-SPL-SL-118/73	73mm wide	51 mb	not compatible (NO spacer)
BB-02-SPL-DH-118/68	68mm wide	51 mb	not compatible (ONE spacer)
BB-02-SPL-DH-118/68E	68mm wide	51 mb	compatible (NO spacer)
BB-02-SPL-DH-118/73	73mm wide	51 mb	not compatible (NO spacer)
BB-02-SPL-DH-118/73E	73mm wide	51 mb	compatible (NO spacer)
BB-02-SPL-XR-113/68	68mm wide	48.5 mb	not compatible (NO spacer)
BB-02-SPL-XR-113/68E	68mm wide	48.5 mb	compatible (NO spacer)
BB-02-SPL-XR-113/73	73mm wide	48.5 mb	not compatible (NO spacer)
BB-02-SPL-XR-118/68	68mm wide	51 mb / 46.5 road t.	not compatible (ONE spacer)
BB-02-SPL-XR-118/68E	68mm wide	51 mb	compatible (NO spacer)
BB-02-SPL-XR-118/73	73mm wide	51 mb	not compatible (NO spacer)
BB-02-SPL-XR-118/73E	73mm wide	51 mb	compatible (NO spacer)

Model#	BB Shell	Chainline	E-type FD or Chainguide
BB-02-SQ-XR-113/68	68MM wide	48.5 mb	not compatible (ONE spacer)
BB-02-SQ-XR-113/68E	68MM wide	48.5 mb	compatible (NO spacer)
BB-02-SQ-XR-113/73	73MM wide	48.5 mb	not compatible (NO spacer)