



Dual Slalom

GENERAL SPECIFICATIONS

- This fork is specifically designed for Downhill use. It is damped by two sealed hydraulic cartridges and sprung by a mechanical coil spring system.
- The sliders consist of two pieces: the top half houses the seal assembly and the pilot bushings, whereas the bottom supports wheel axle and brake caliper mount.
- The wheel axle mount shifted to the front is derived from the motorcycle industry. Fastening bolts on either side clamp the axle in place. Axle is available in two sizes:
 - 20 mm (code MARZOCCHI 850601) standard
 - 17 mm (code MARZOCCHI 850602).

 **NOTE:** These instructions cover the special parts specific to this model. For further information, please read the attached instructions relevant to the “Z1” model (code 900484).

FRONT WHEEL FIXING

 **IMPORTANT:** fixing the front wheel properly as specified in the instructions given below is essential for the proper operation of this fork and all related devices, and therefore for safe riding.

ASSEMBLY

FIG. 1

Insert the complete wheel between the sliders and the wheel axle (31) into the slider with the fastening bolts (32) from the right. Axle (31) and wheel hub must be in contact.

FIG. 1

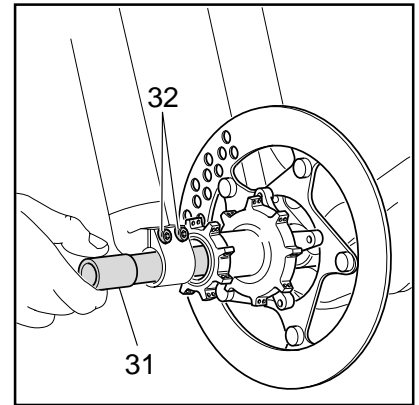

FIG. 2

Fit the axle fastening bolt (33) onto the opposite side and tighten to 20 Nm.

FIG. 2

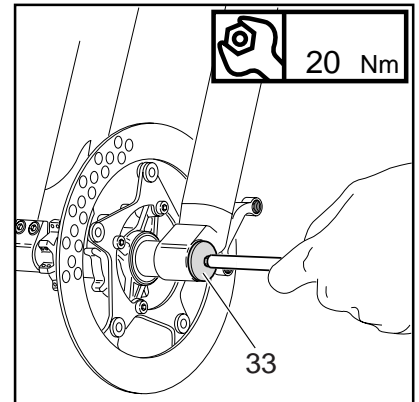
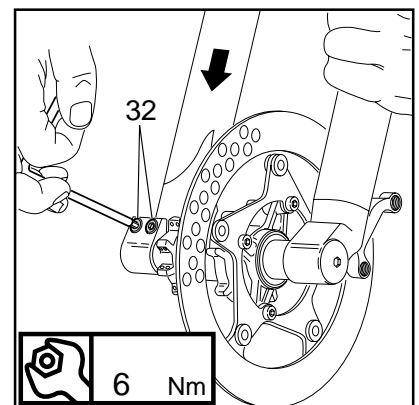

FIG. 3

Compress the fork several times to adjust the sliders onto the wheel axle and then tighten the bolts (32) on the r.h. drop-out to 6 Nm.

FIG. 3





Dual Slalom

DISASSEMBLY

To remove the wheel proceed as follows:

- loosen the bolt (33) that fastens the axle onto the l.h. drop-out;
- loosen the two bolts (32) on the r.h. drop-out;
- push on the partially unscrewed bolt (33) so to push the axle (31) outwards. Then remove the bolt and extract the axle from the opposite side.

FORK EXPLODED VIEW

